

## DFG-30 Door Frame® Guard

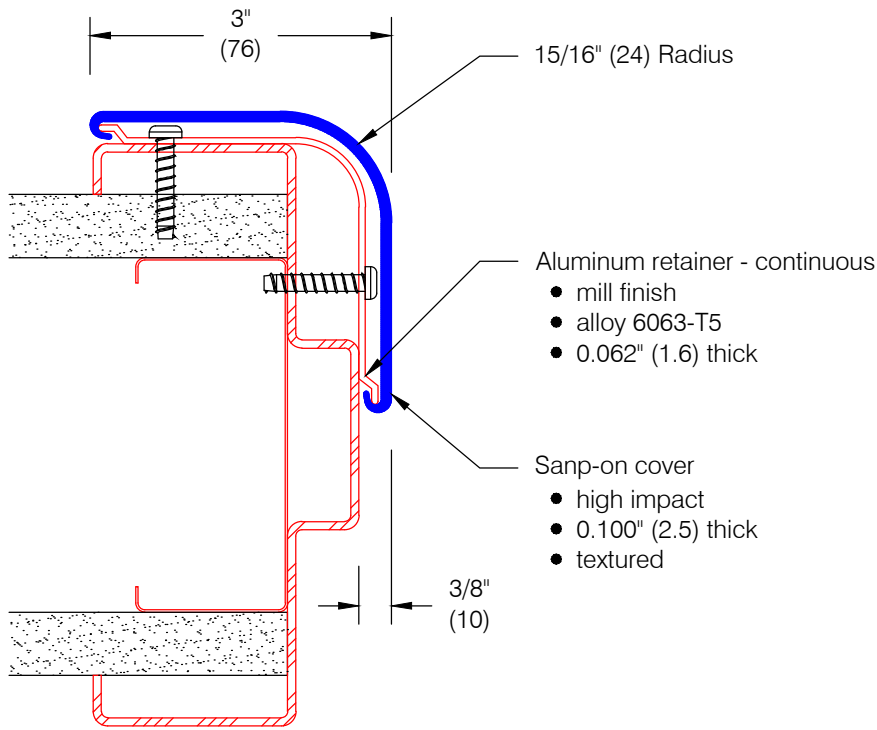

### Features:

- Class A fire rating
- Molded top/bottom caps
- NFPA-252 (UL10b) approved for use on 90 minute wood and 180 minute steel fire rated door assemblies
- Stock length: 4'-0" (1219)

### Finishes:

- Manufacturer's standard colors
- Custom colors available

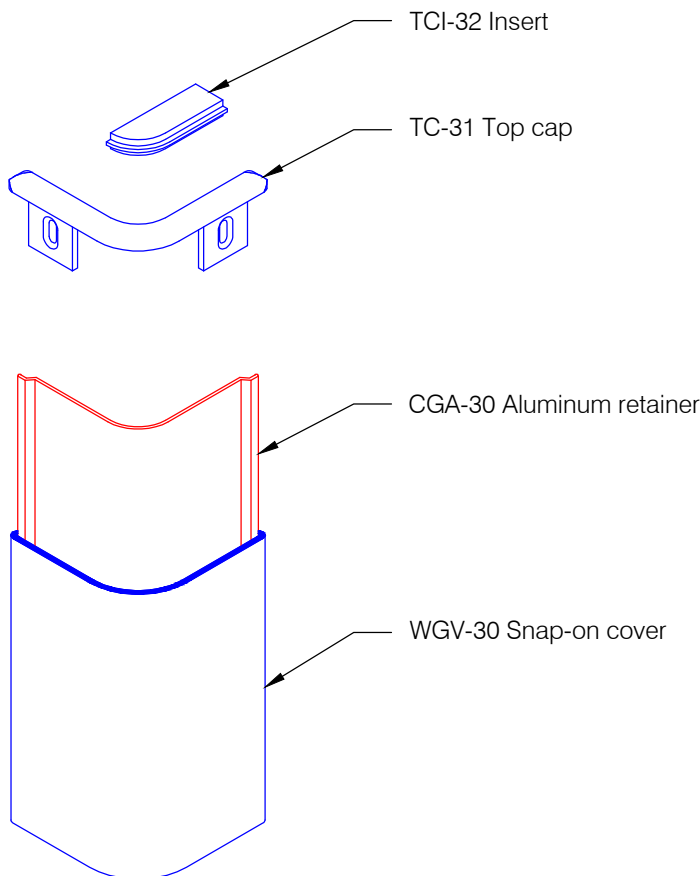

Exploded View

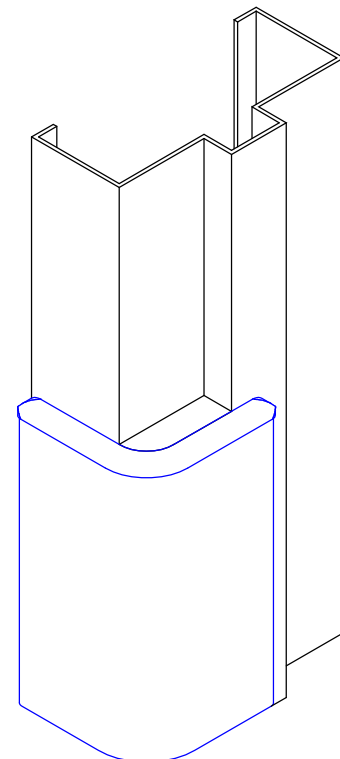

Installed View

Customer :

Project :

Architect :

Sales Rep :

WD.134.0d