

Stainless Steel Crash Rail with Brackets

Installation Instructions

1. Set a laser or chalk line at the desired height. Measure and mark the end points of the crash rail on the wall. Allow at least 2 inches clearance from inside corners and at least 1 inch clearance from all other terminations to allow for end plate attachment (see figure 1.1).
2. Measure and cut the crash rail sections to length for each segment. Take into account the thickness of the end plates. Dry fit the cut lengths on the wall to ensure proper installation. Clean field-cut edges on the crash rail covers as necessary.
3. Install the mounting brackets, hitting studs or continuous backing if possible (see figure 3.1 and 3.1a). Install end plate brackets 1/8-inch to 1/4-inch shy of the end points to ensure that end plates will pull tight against the crash rail. Install the 3-inch splice brackets centered at each crash rail splice to ensure the butting crash rails are secured. Install standard brackets at all other locations so that spacing does not exceed 32 inches on center.
4. Install the crash rail covers by hooking the top edge of the rail cover over the top lip of the mounting brackets (see figure 4.1 and 4.1a). The bottom edge of the crash rail covers should rest on the bottom lip of the mounting brackets.
5. Attach the end plates to the end plate brackets located at each end of the crash rail segments (see figure 5.1).
6. Secure the crash rail cover to the mounting brackets with stainless steel pop rivets through the bottom side (see figure 6.1 and 6.1a). Drill holes through the bottom edge of the crash rail that align with the holes in the mounting brackets. Make sure to press the crash rail firmly against the wall while drilling and installing the pop rivets.

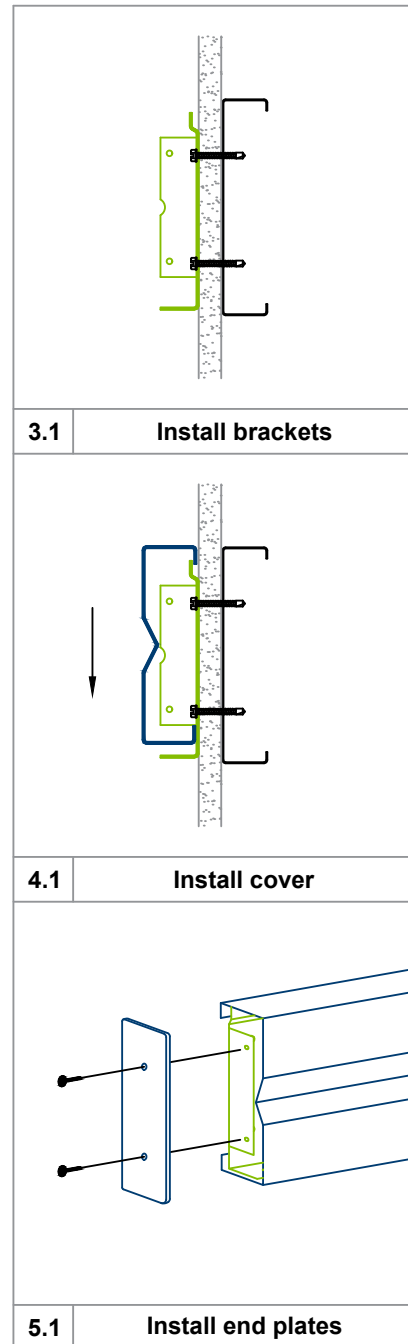

DISCLAIMER: Please read all instructions before beginning installation. These guidelines are provided in good faith to help prevent any problems caused by errors in installation. The manufacturer of this product shall not be held responsible for installation actions taken or not taken. There are many details of installation that are assumed to be general construction knowledge to experienced installers; which are not included in these instructions. These installation guidelines are intended to be strictly recommendations and are not to serve as a step-by-step, fail-safe installation checklist. Selection of an experienced installer is the sole responsibility of the project owner and architect. Protek Systems, Inc. does not accept any responsibility for job failure resulting from or associated with improper site environmental conditions and installation failure due to expansion contraction issues.

Stainless Steel Crash Rail with Brackets

Important

1. Acclimate materials to the installation environment for 24 hours prior to installation. Maintain a temperature controlled environment during and after installation.
2. To cut the material, use a metal chop saw with abrasive cut-off wheel. De-burr cut edges with a file or flap disk. If there are any surface burns, remove with scotch-brite pad.
3. To drill the material, use a good quality high-speed steel bit and a variable drill with good torque. For anything larger than a 1/8-inch hole, use a step drill bit. Use lubricant and clamp the item securely. Use a punch and hammer to make a dimple where the hole is to be drilled. This will keep the drill bit from wandering.

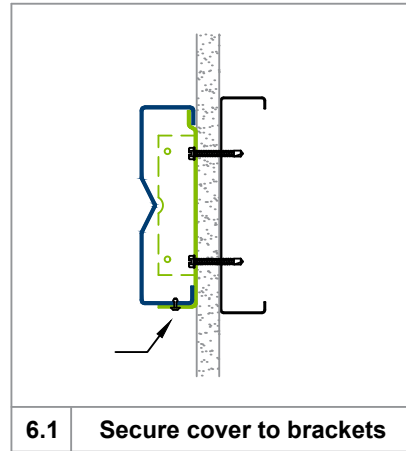

6.1 Secure cover to brackets

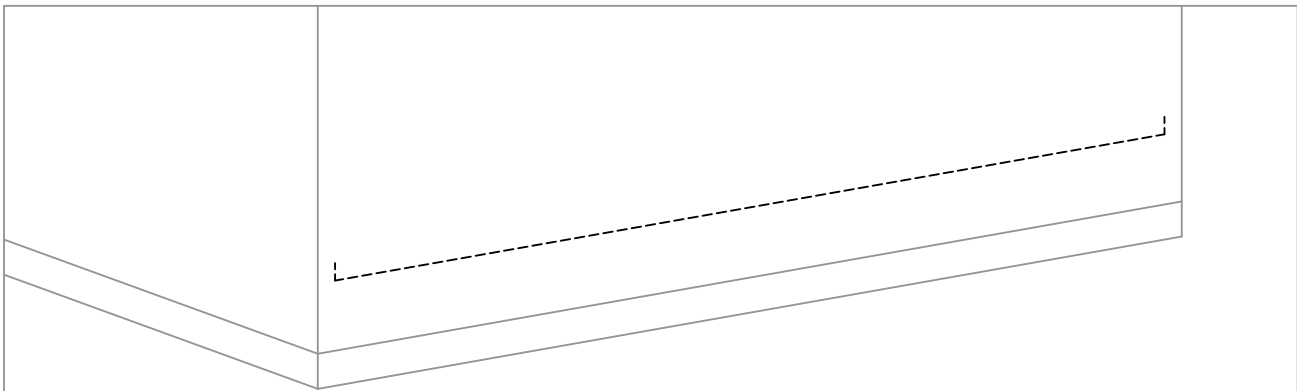

1.1 Set chalk line and mark end points

DISCLAIMER: Please read all instructions before beginning installation. These guidelines are provided in good faith to help prevent any problems caused by errors in installation. The manufacturer of this product shall not be held responsible for installation actions taken or not taken. There are many details of installation that are assumed to be general construction knowledge to experienced installers; which are not included in these instructions. These installation guidelines are intended to be strictly recommendations and are not to serve as a step-by-step, fail-safe installation checklist. Selection of an experienced installer is the sole responsibility of the project owner and architect. Protek Systems, Inc. does not accept any responsibility for job failure resulting from or associated with improper site environmental conditions and installation failure due to expansion contraction issues.

Stainless Steel Crash Rail with Brackets

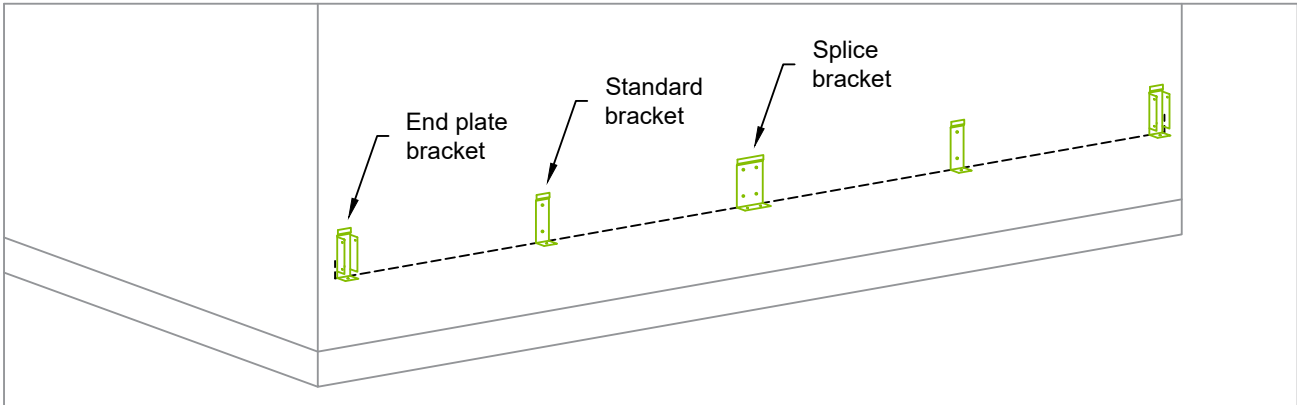

3.1a

Install brackets

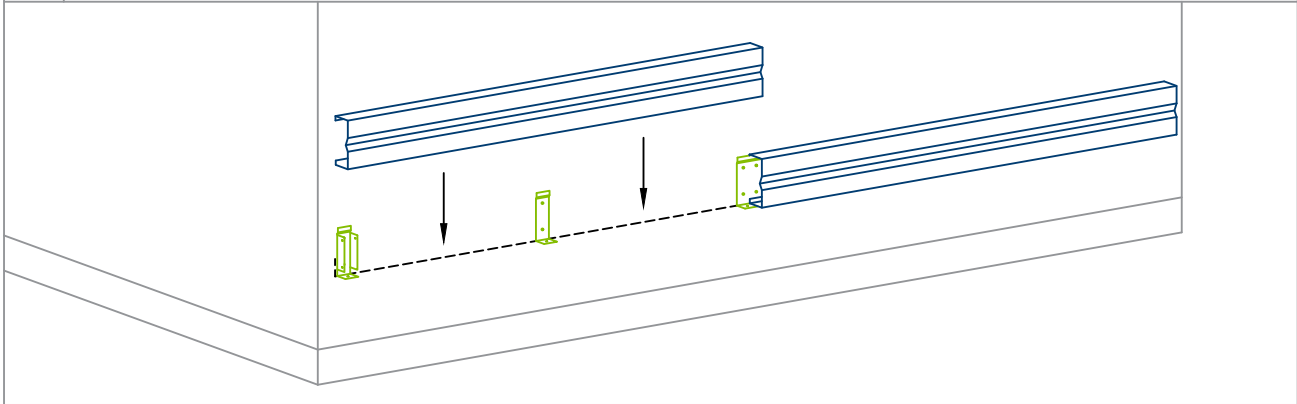

4.1a

Install crash rail covers

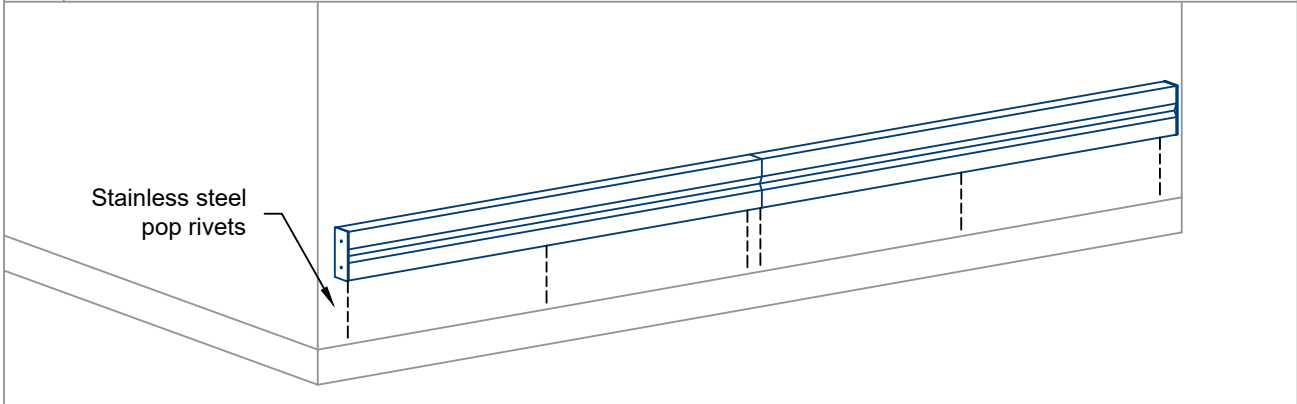

6.1a

Secure crash rail covers to mounting brackets

DISCLAIMER: Please read all instructions before beginning installation. These guidelines are provided in good faith to help prevent any problems caused by errors in installation. The manufacturer of this product shall not be held responsible for installation actions taken or not taken. There are many details of installation that are assumed to be general construction knowledge to experienced installers; which are not included in these instructions. These installation guidelines are intended to be strictly recommendations and are not to serve as a step-by-step, fail-safe installation checklist. Selection of an experienced installer is the sole responsibility of the project owner and architect. Protek Systems, Inc. does not accept any responsibility for job failure resulting from or associated with improper site environmental conditions and installation failure due to expansion contraction issues.